

ЛАМІЯ / ЛАМИЯ

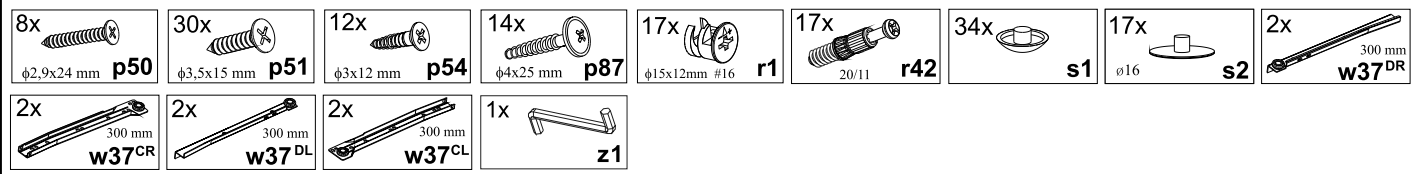
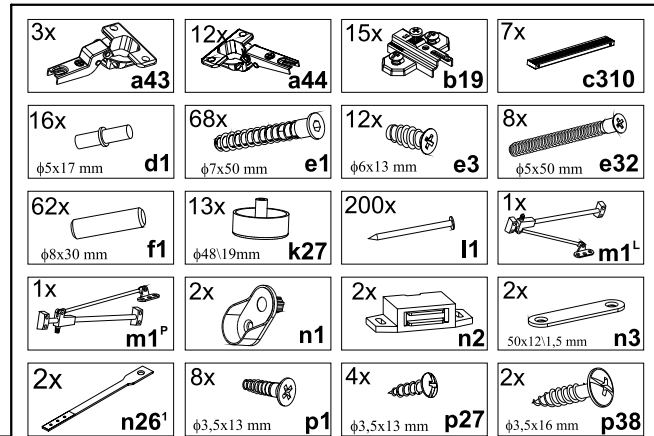
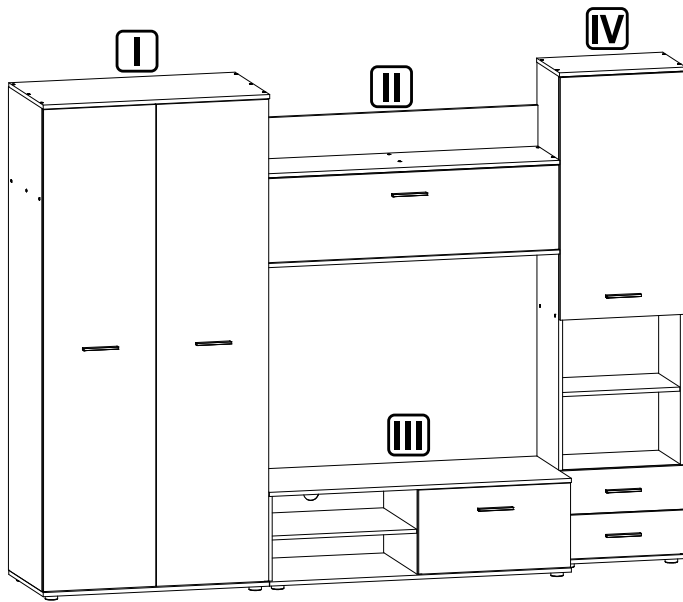
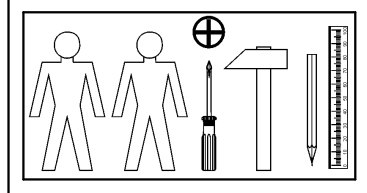

ЛАМІЯ / ЛАМИЯ

I Шафа / Шкаф

A	B	C	D	
1	M64-001	1880	446	6/6
2	M64-101	1886	495	2/6
3	M64-102	1886	495	2/6
4	M64-201	900	511	3/6
5	M64-202-01	900	511	3/6
6	M64-301	867	495	2/6
7	M64-1901	1913	447	4/6
8	dr-862	862	22	2/6
9	lh-1884	1884	14	2/6

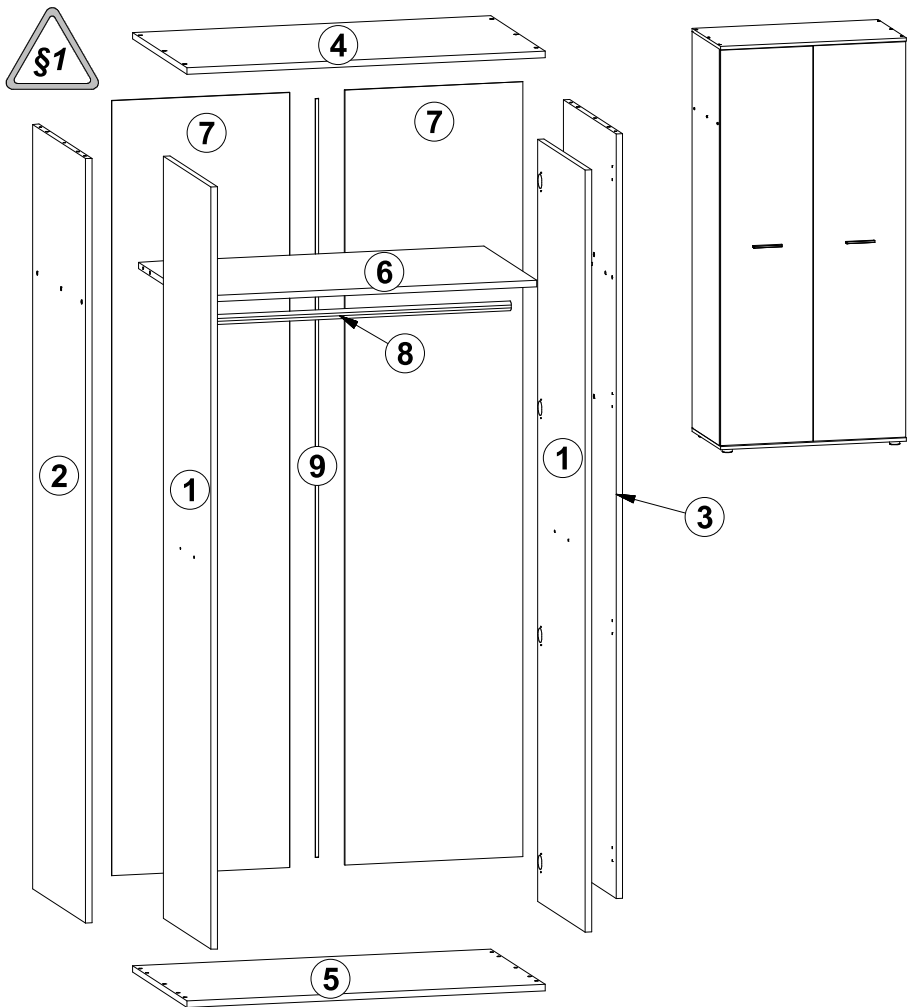

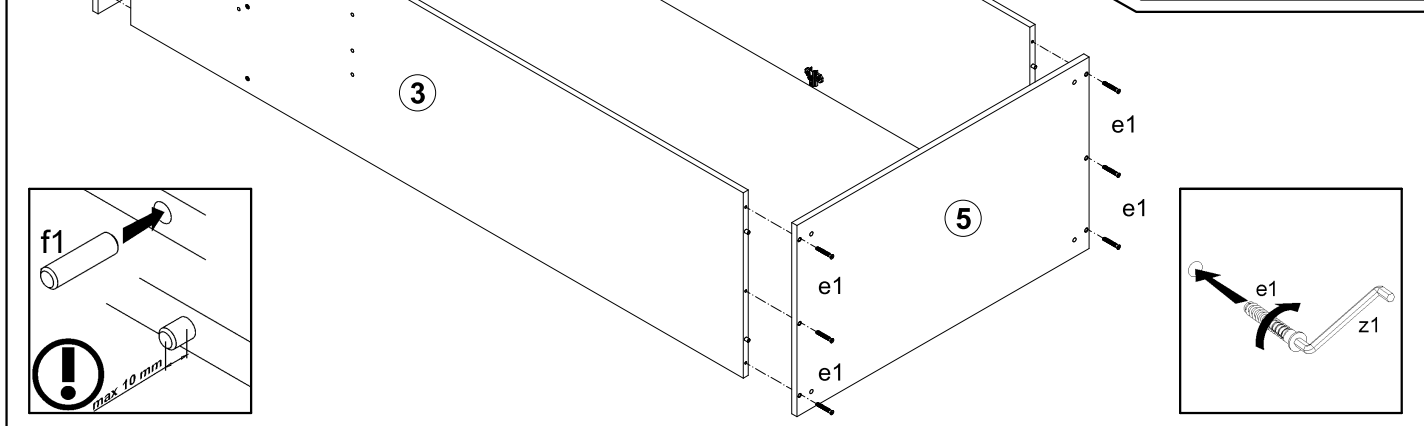
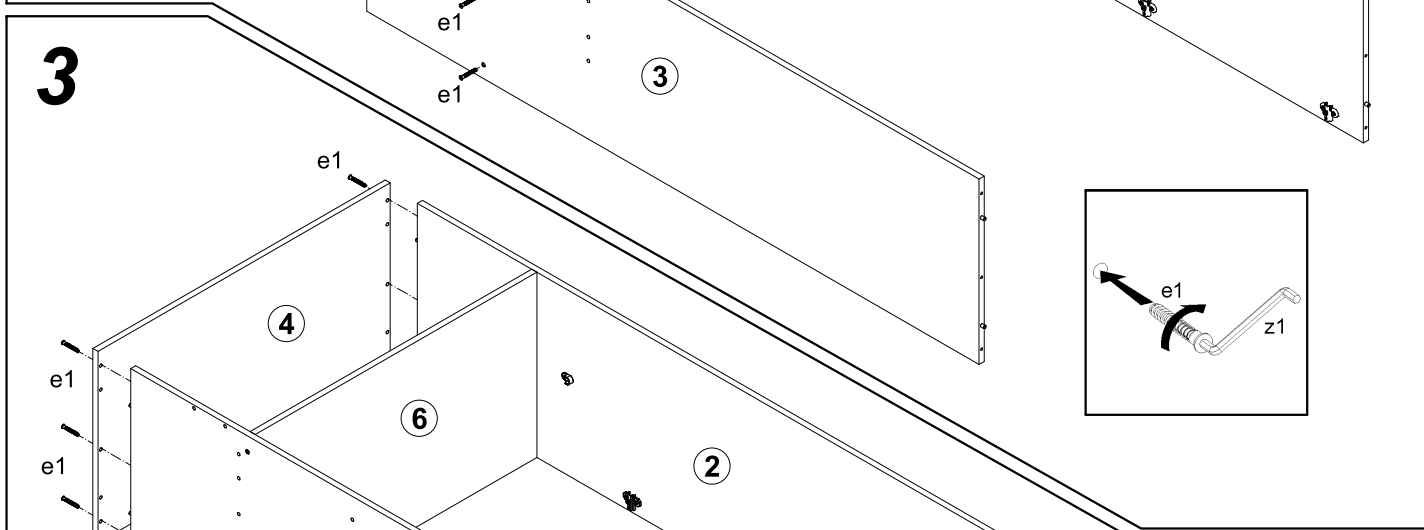
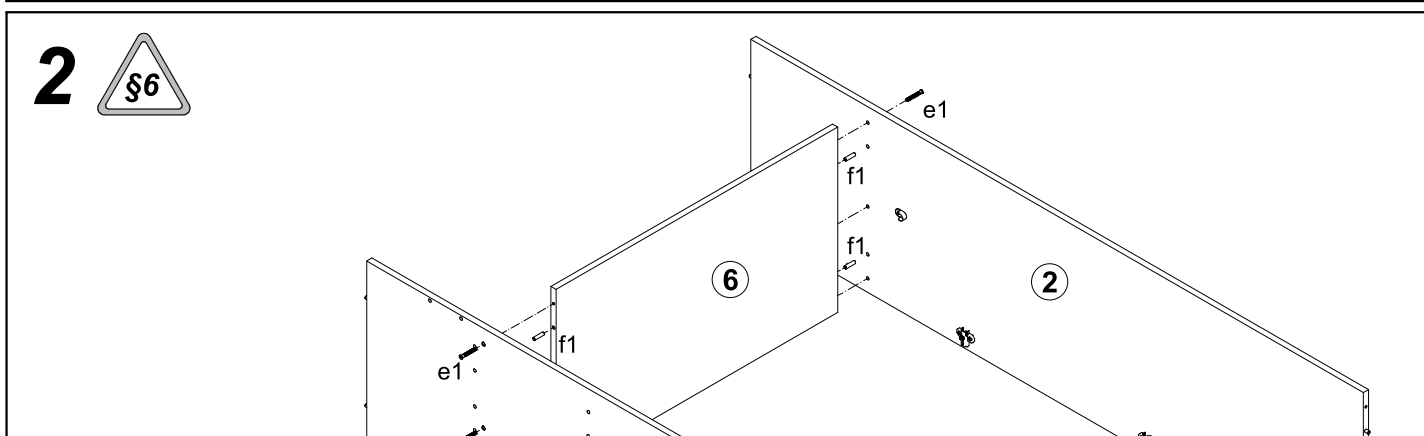
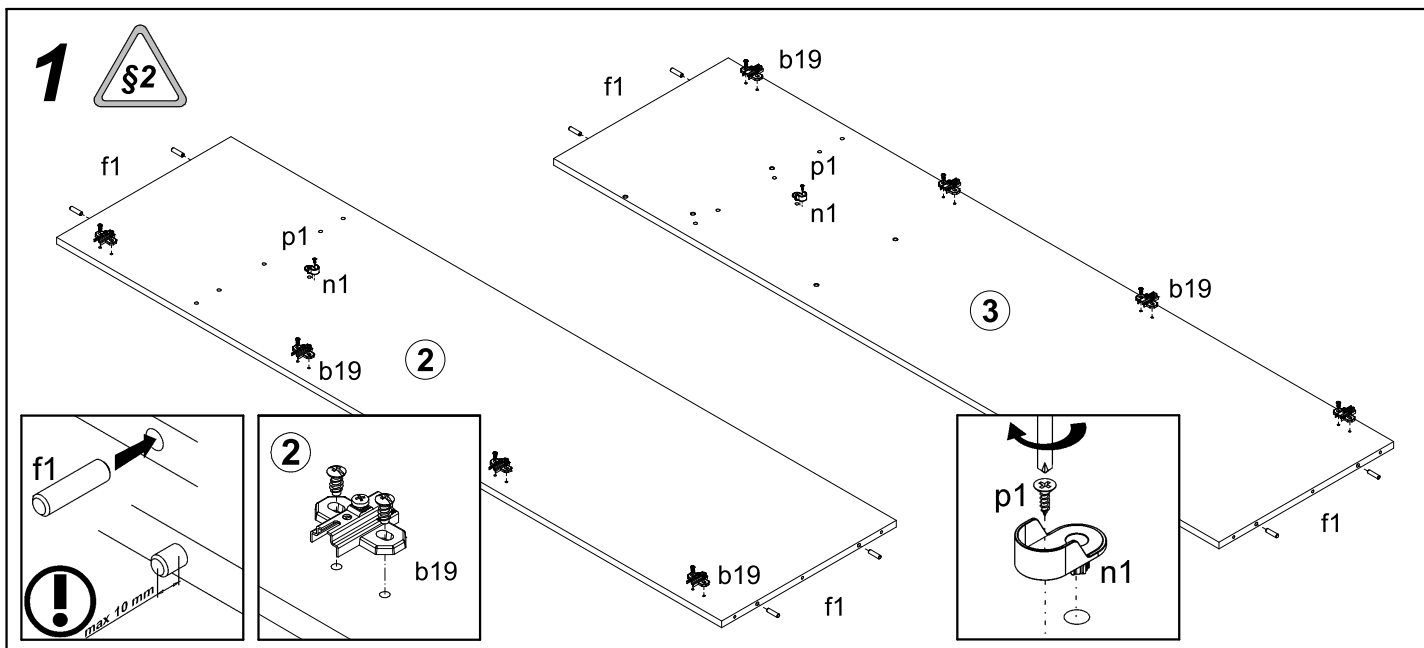

4

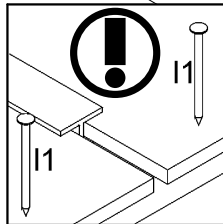
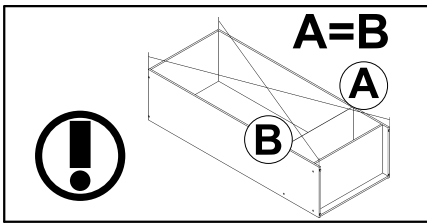
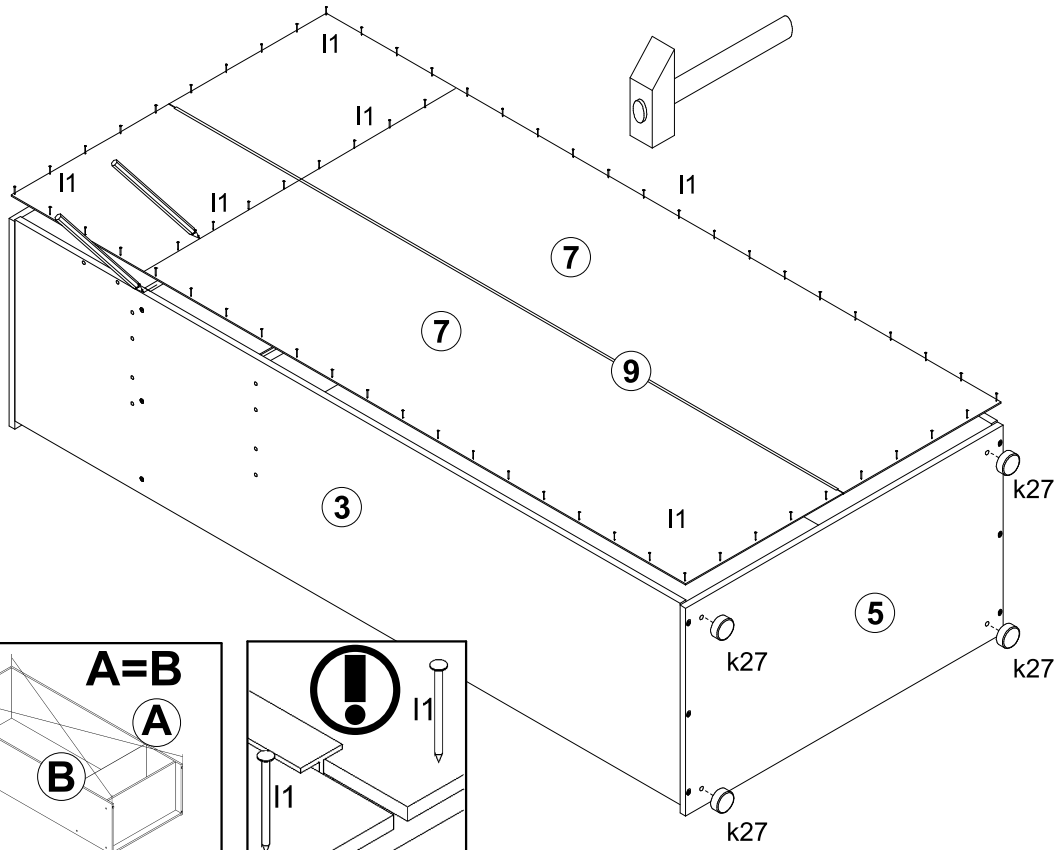

5

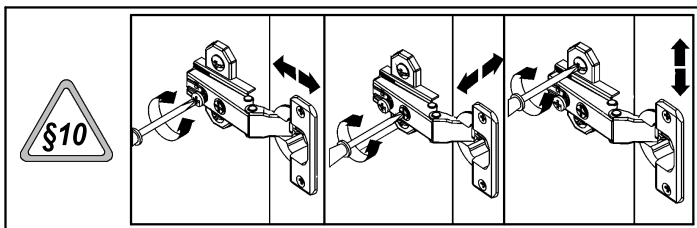
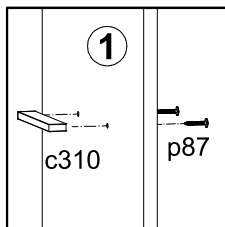
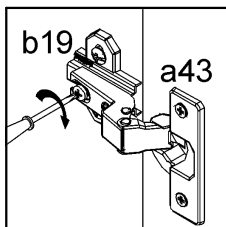
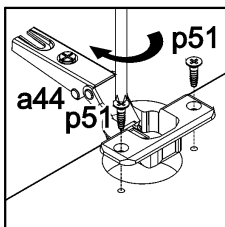
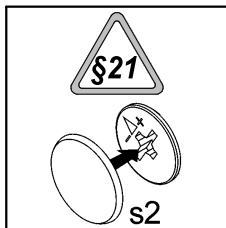
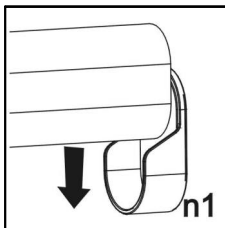
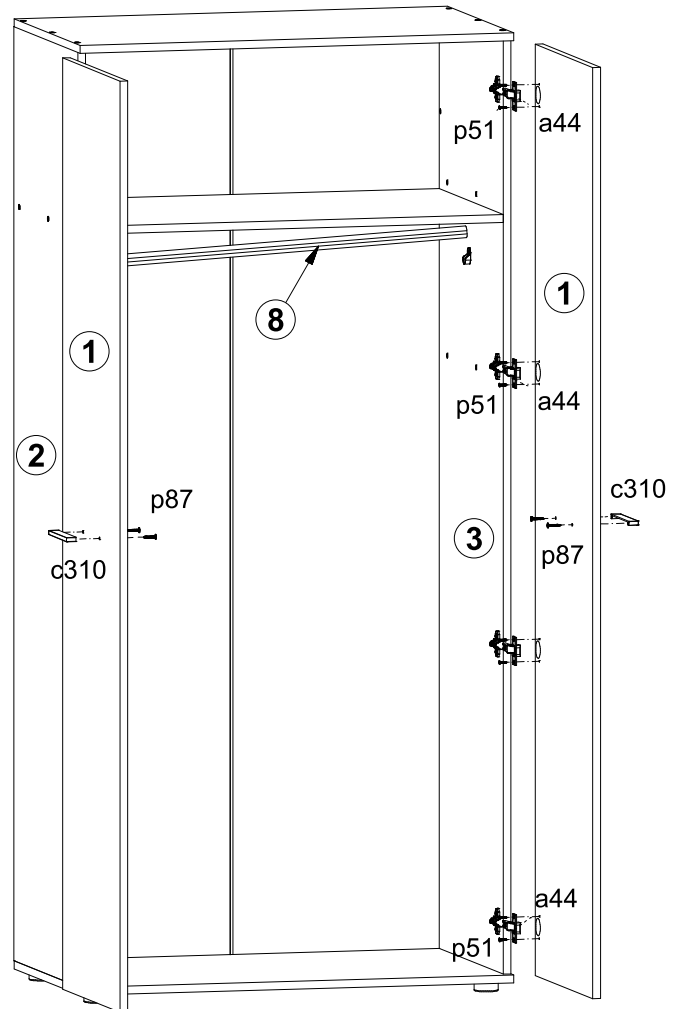

ЛАМІЯ / ЛАМИЯ



Полиця / Полка

A	B	C	D	
1	M64-004	1195	328	6/6
2	M64-105	334	323	1/6
3	M64-106	334	243	1/6
4	M64-205	1200	339	3/6
5	M64-206	1200	339	3/6
6	M64-401	1200	160	3/6
7	M64-904	1195	361	4/6

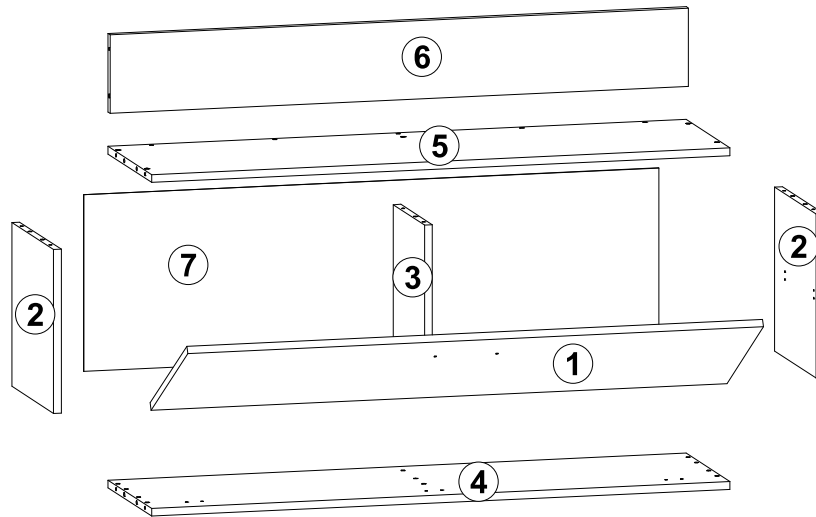
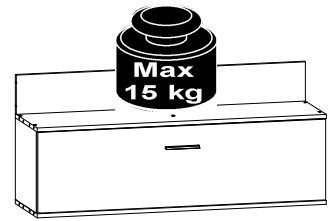

6

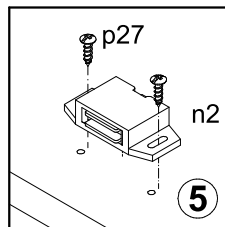
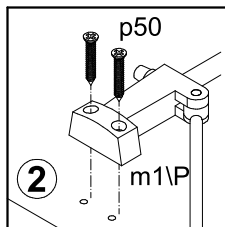
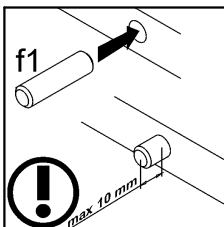
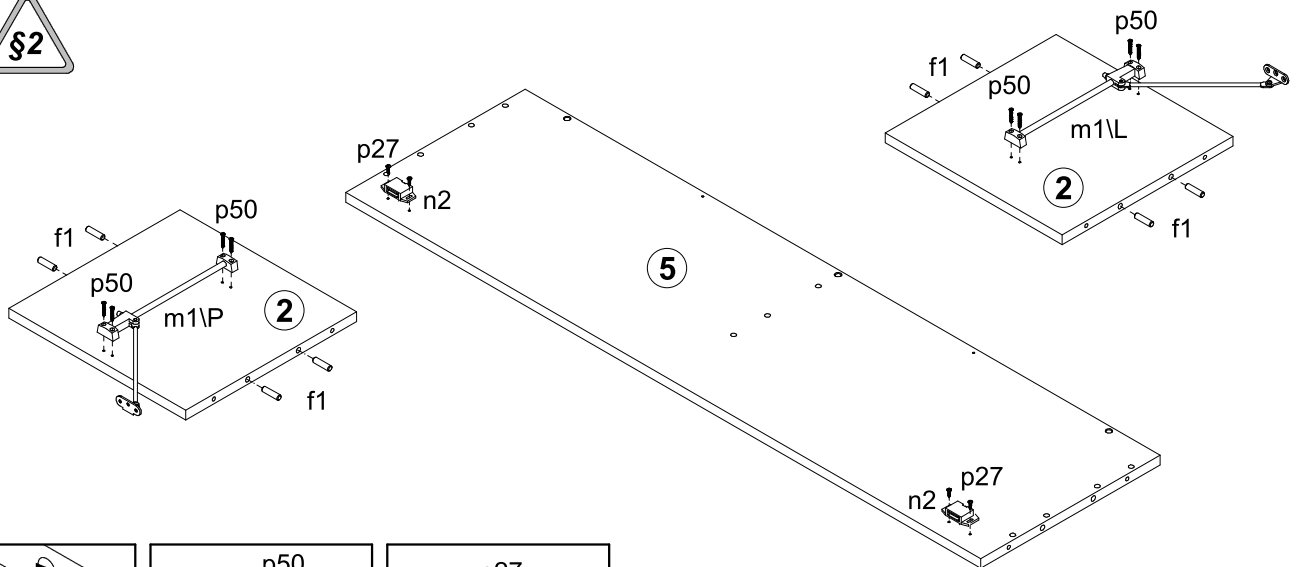

7

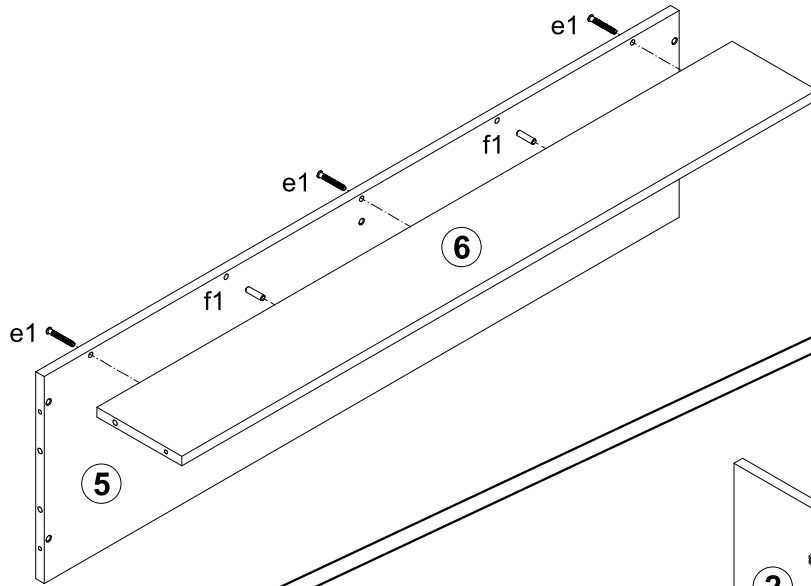
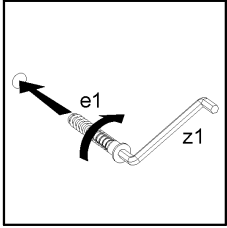
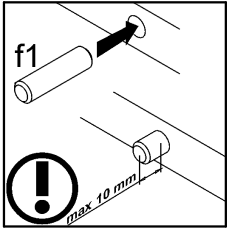

8

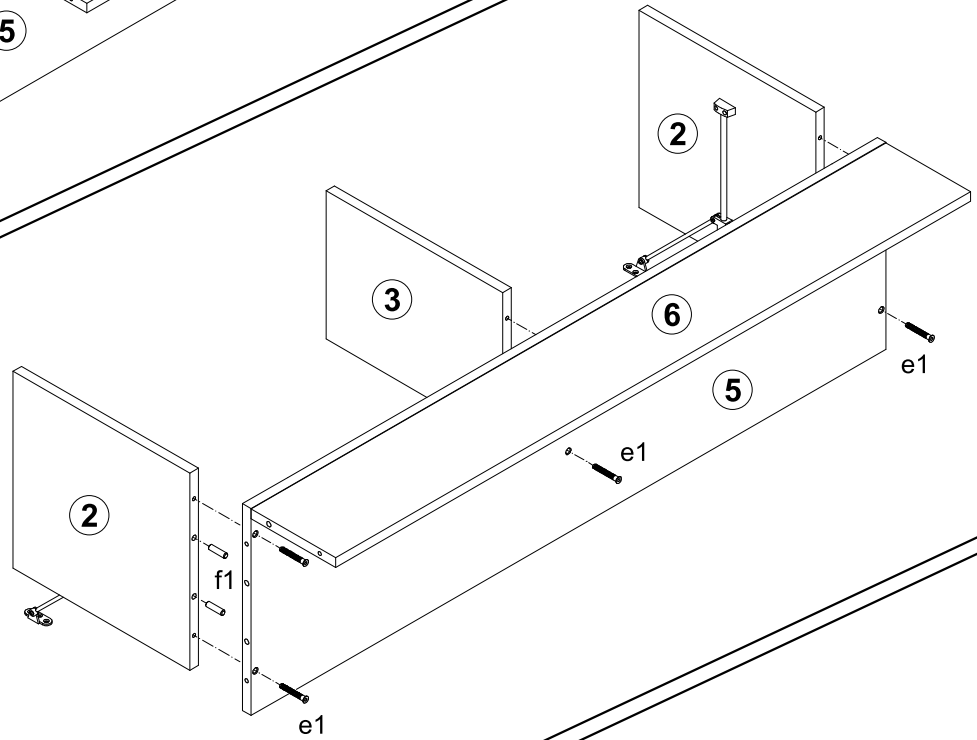
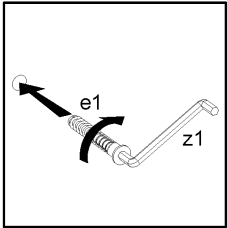
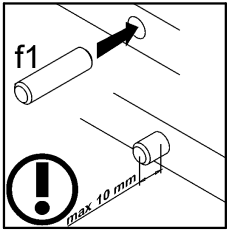

9

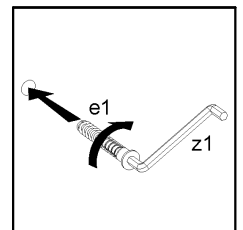
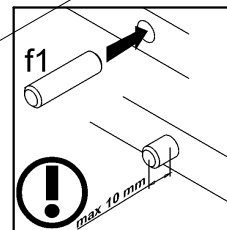
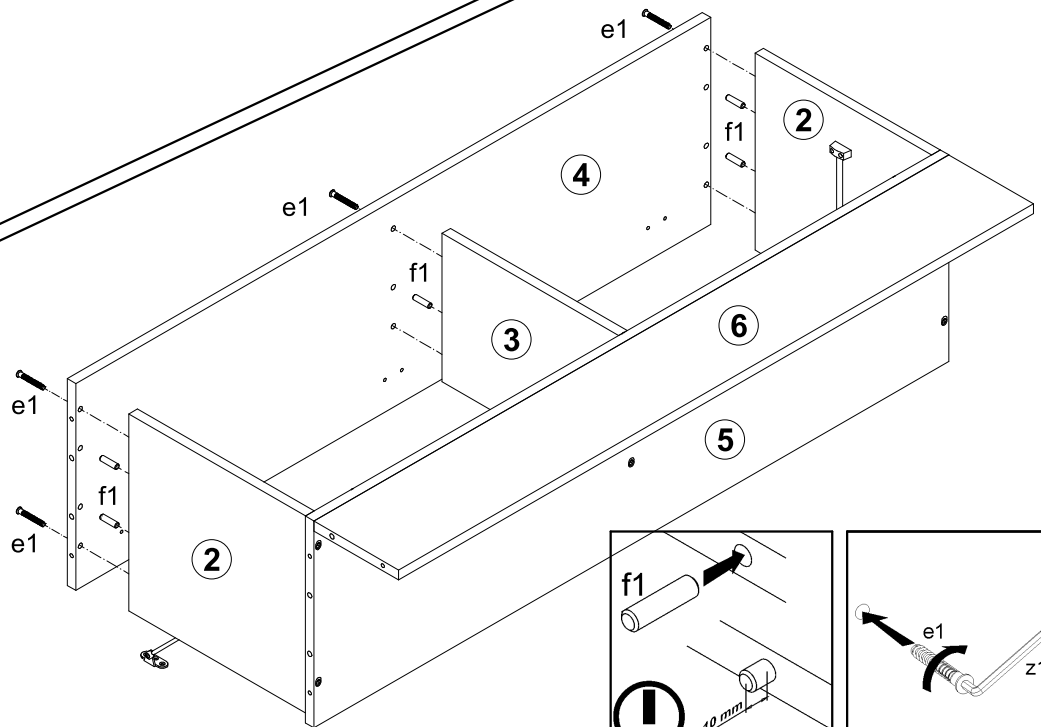

10

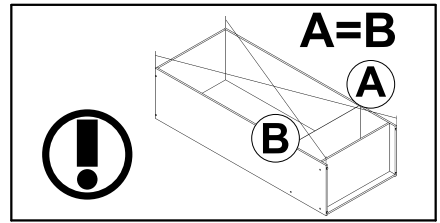
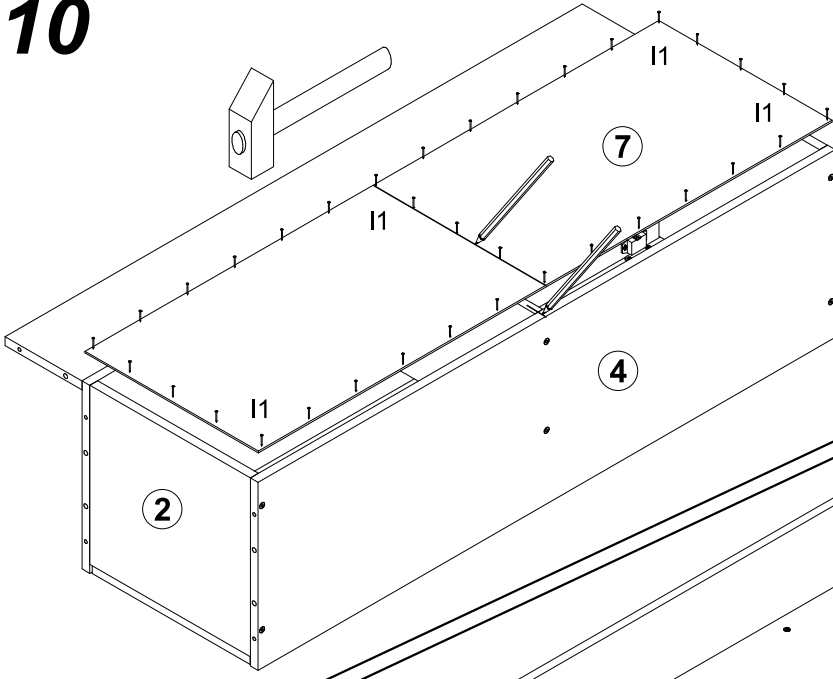

11

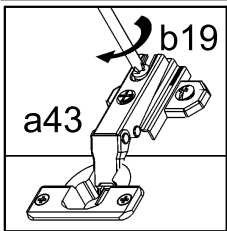
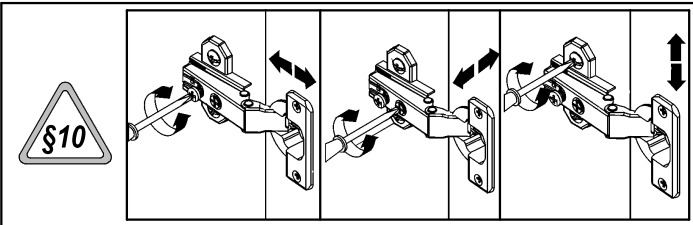
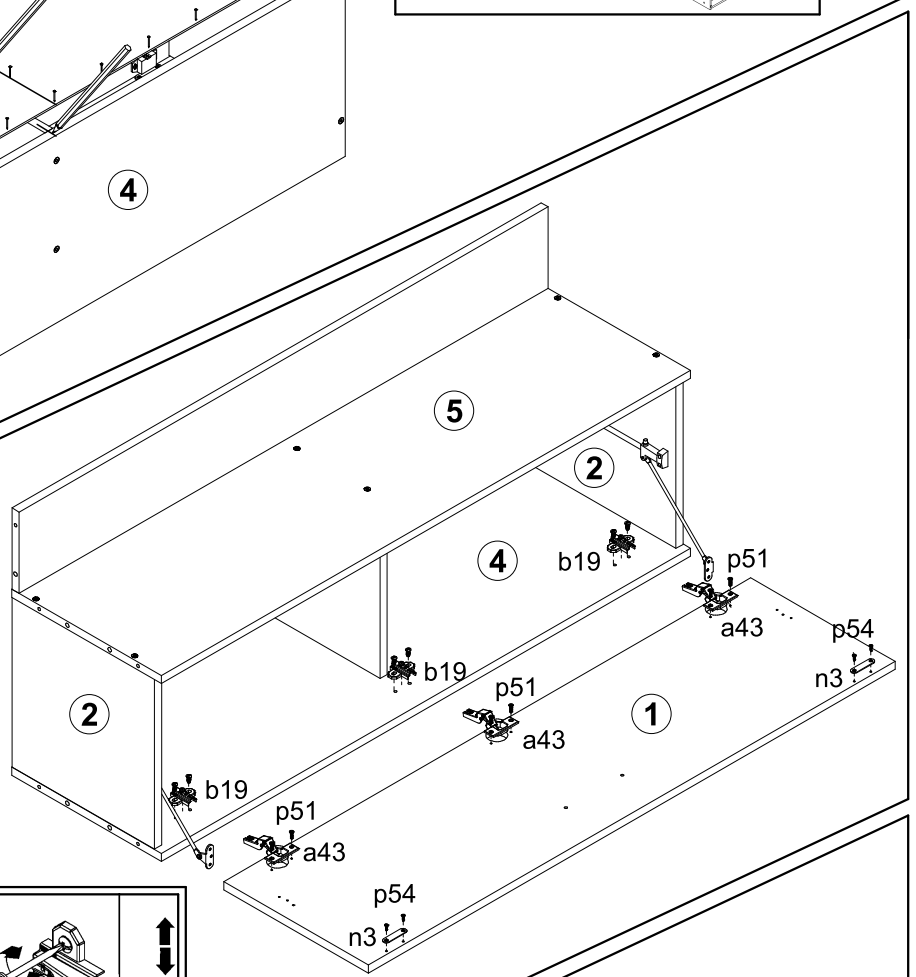
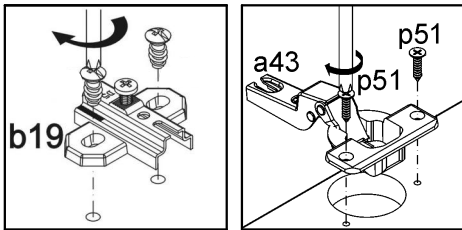

12

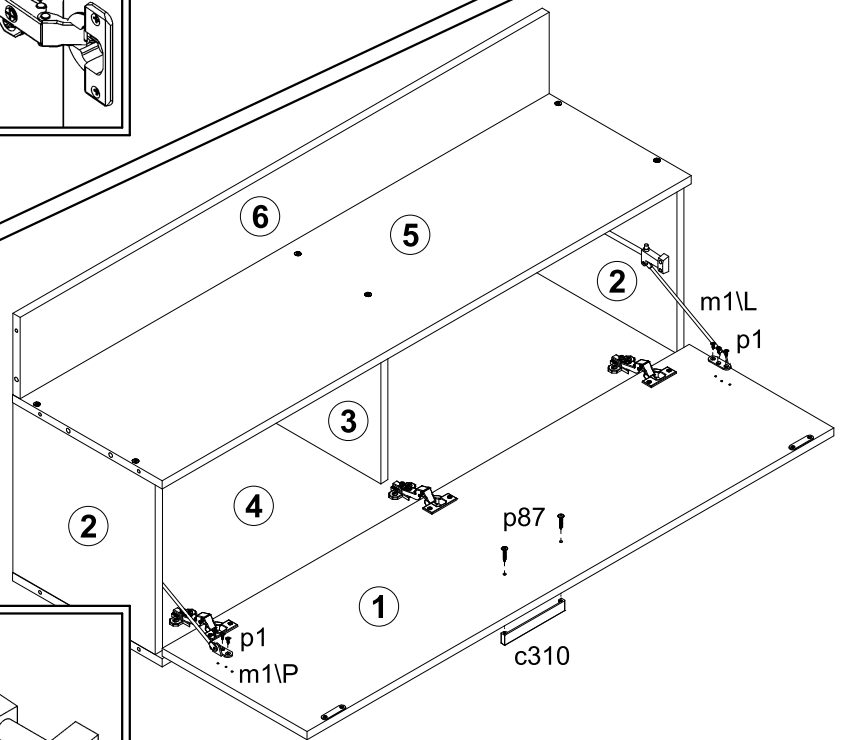
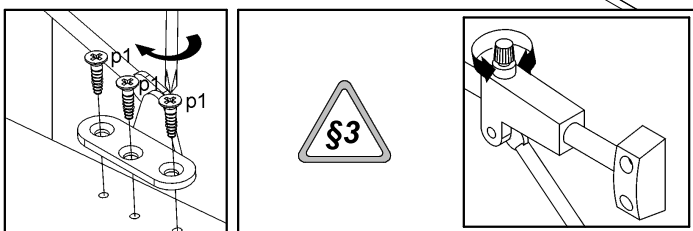

ЛАМІЯ / ЛАМИЯ



Тумба РТВ

A	B	C	D	
1	M64-005	328	603	6/6
2	M64-108	334	495	2/6
3	M64-109	334	495	2/6
4	M64-110	334	495	2/6
5	M64-207	1200	511	3/6
6	M64-208-01	1200	511	3/6
7	M64-305	574	491	2/6
8	M64-905	1195	361	4/6

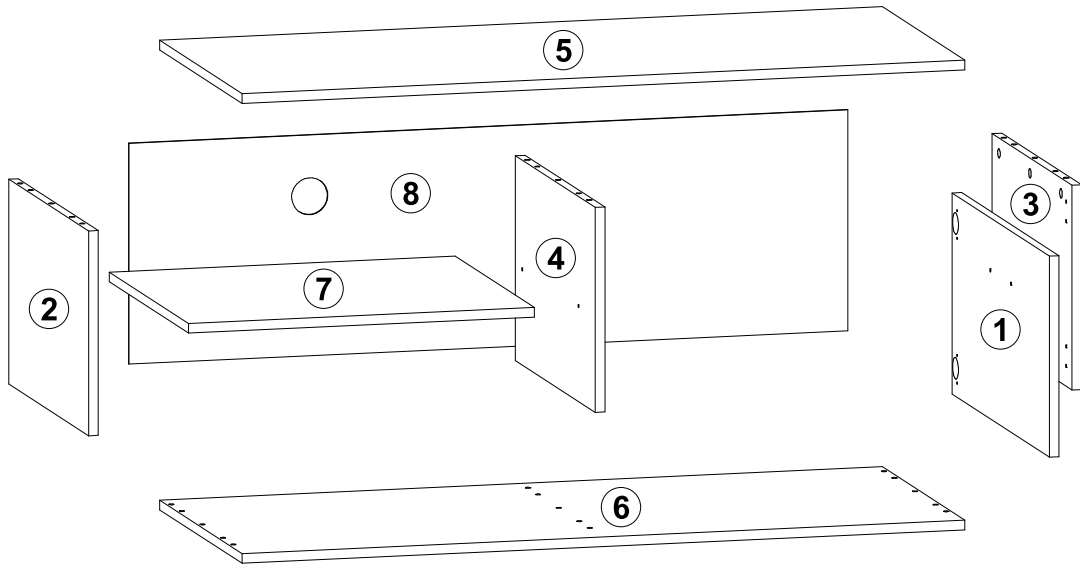
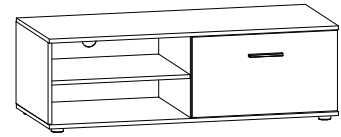

13

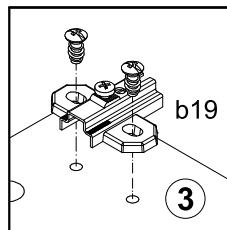
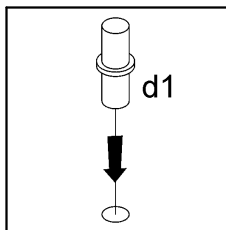
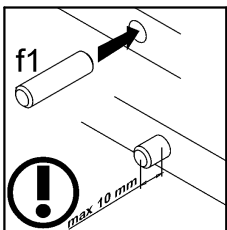
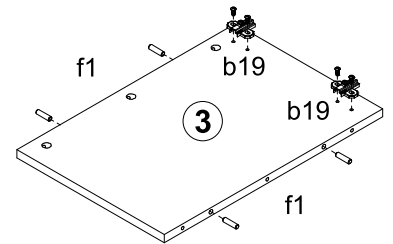
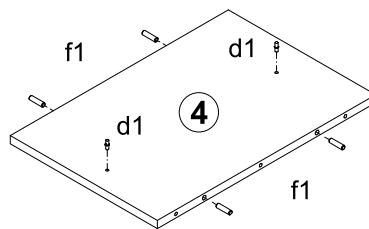
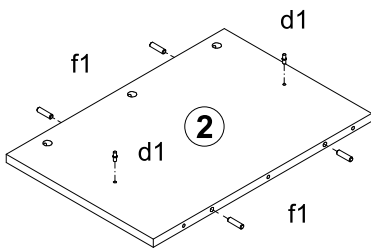

14

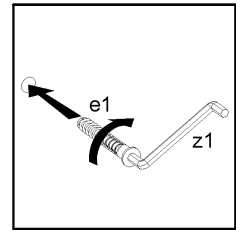
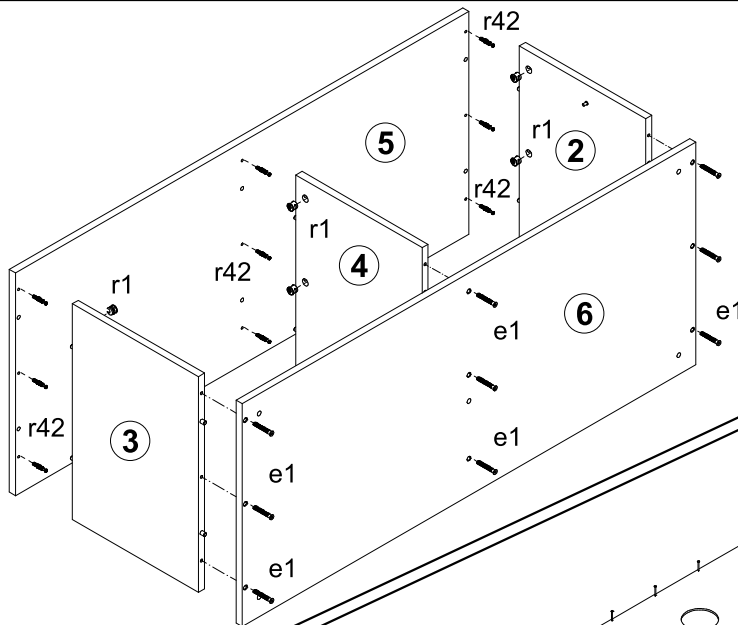
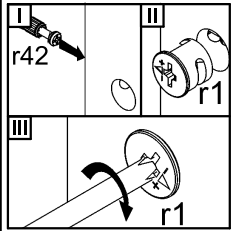
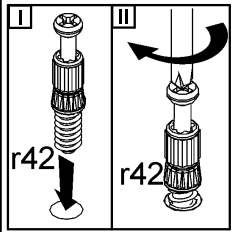

15

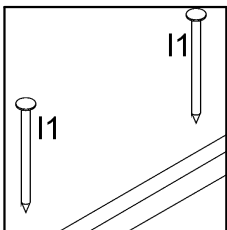
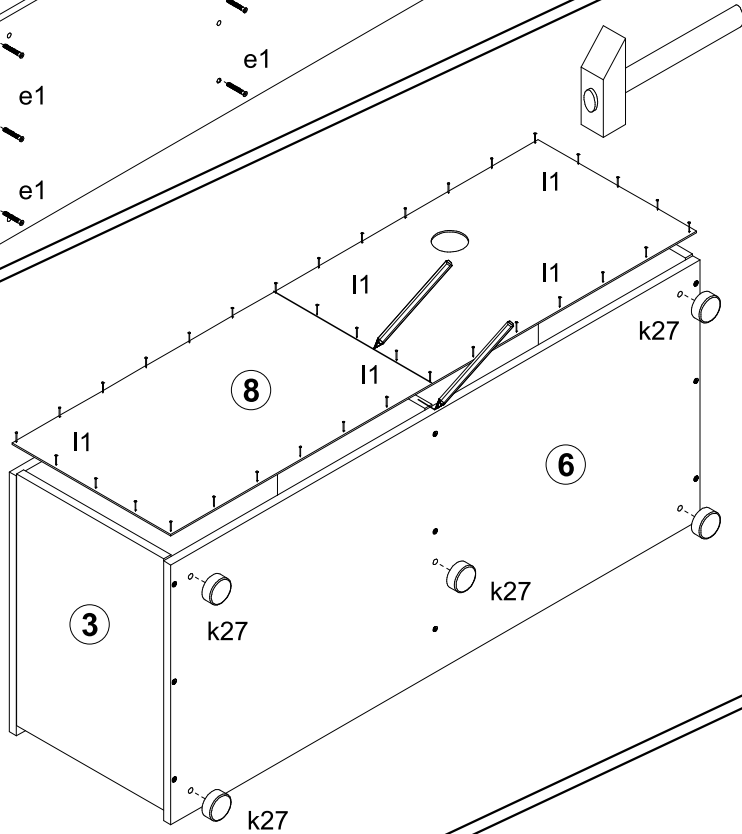
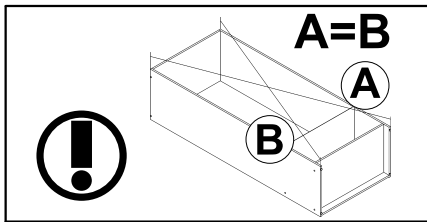

16

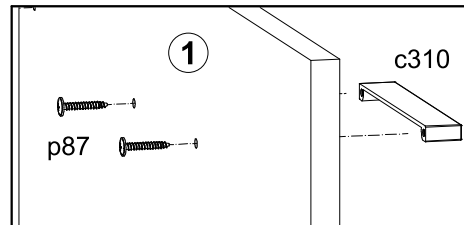
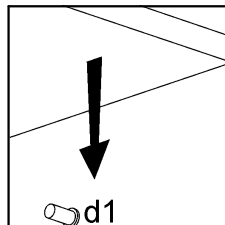
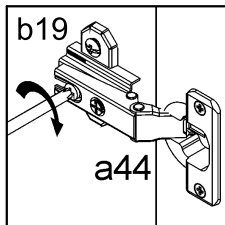
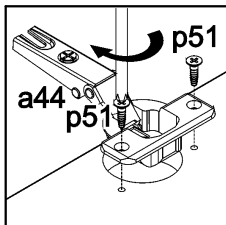
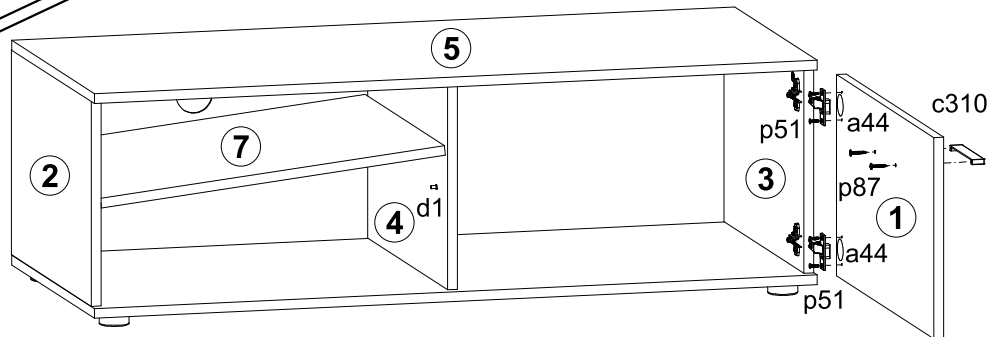

ЛАМІЯ / ЛАМИЯ

IV Пенал

A	B	C	D	
1	M64-002	496	171	6/6
2	M64-003	946	496	6/6
3	M64-103	1886	323	1/6
4	M64-104	1886	323	1/6
5	M64-203	501	339	3/6
6	M64-204-01	501	339	3/6
7	M64-302	468	323	1/6
8	M64-303	466	319	1/6
9	M64-902	1913	496	4/6
10	M64-903	426	299	4/6
11	ZS2-507	300	120	2/6
12	ZS2-508	300	120	2/6
13	ZS2-5018	411	120	2/6

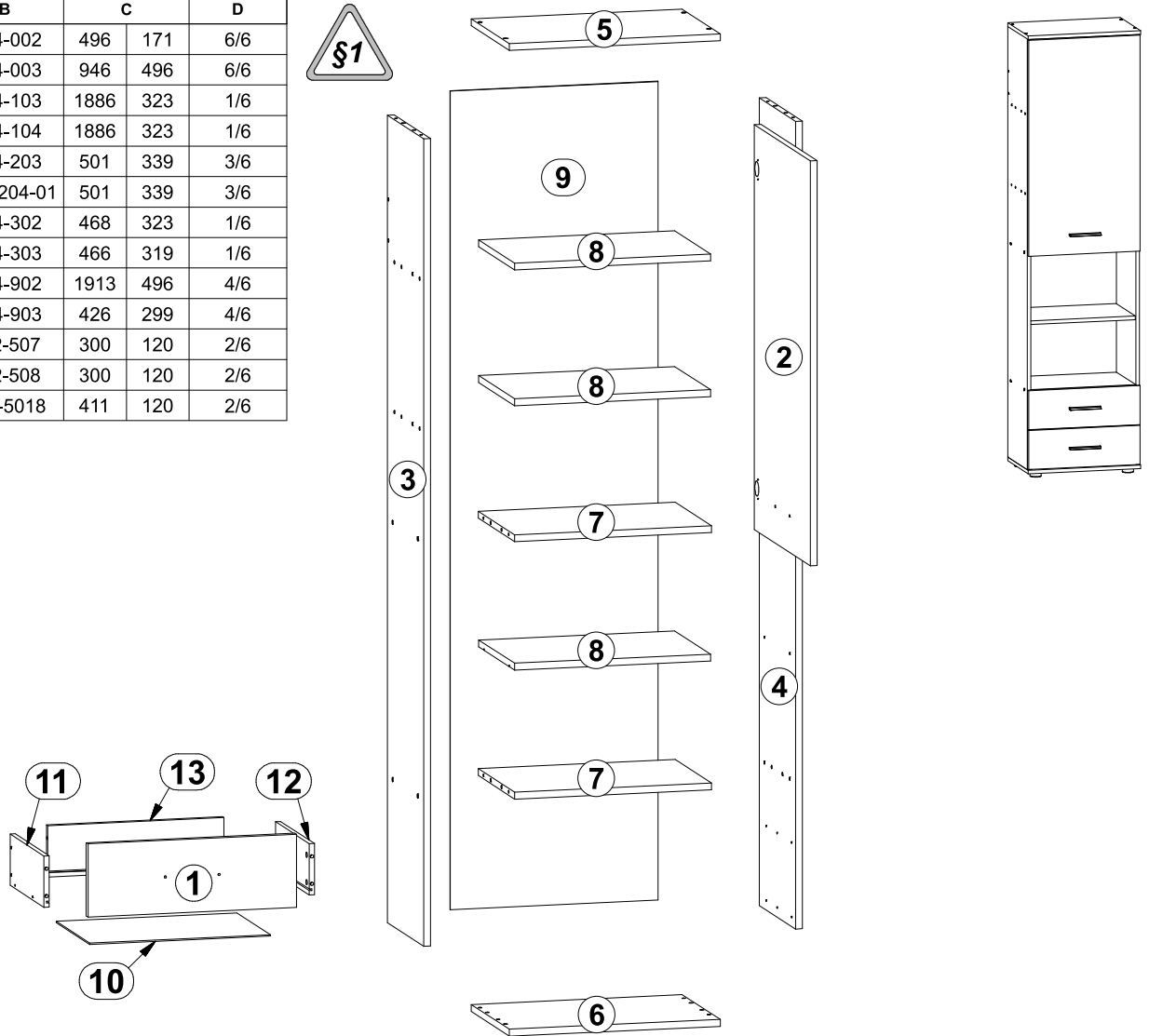

17

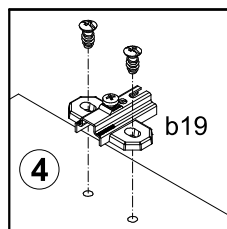
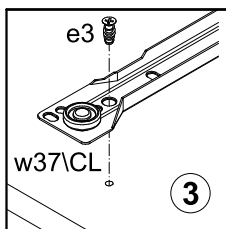
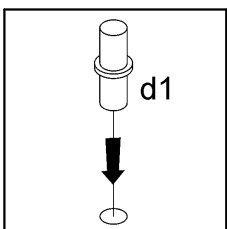
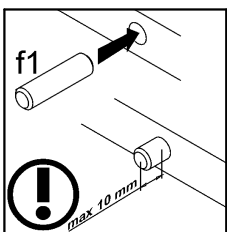
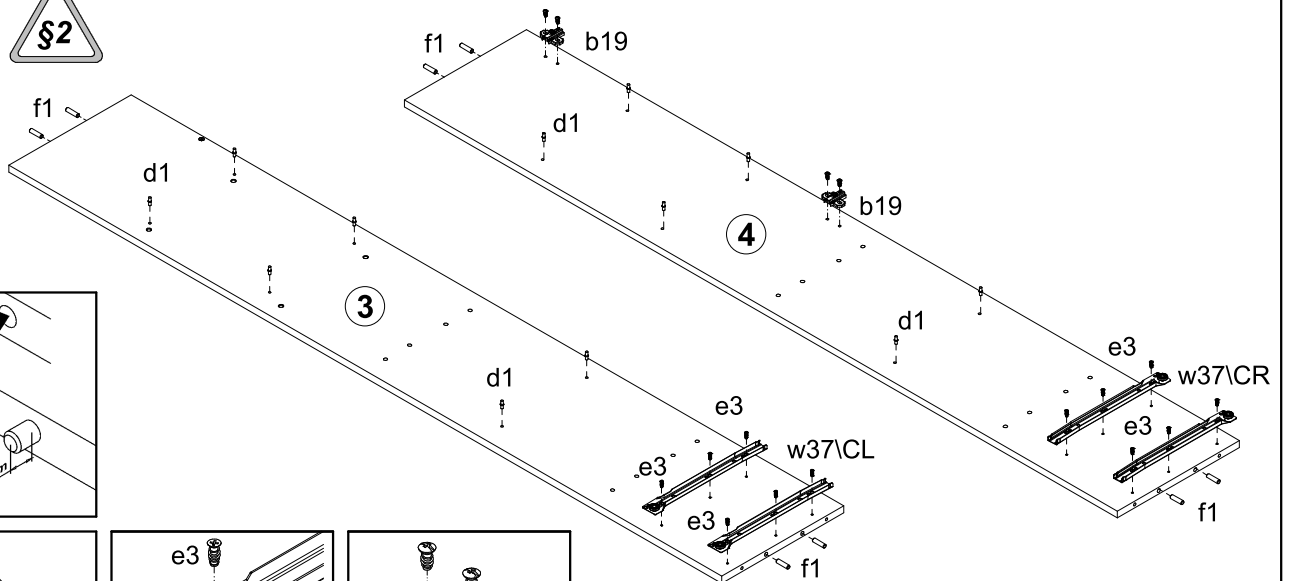

18

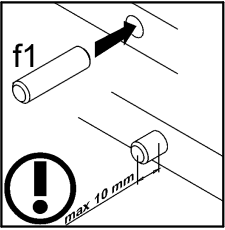
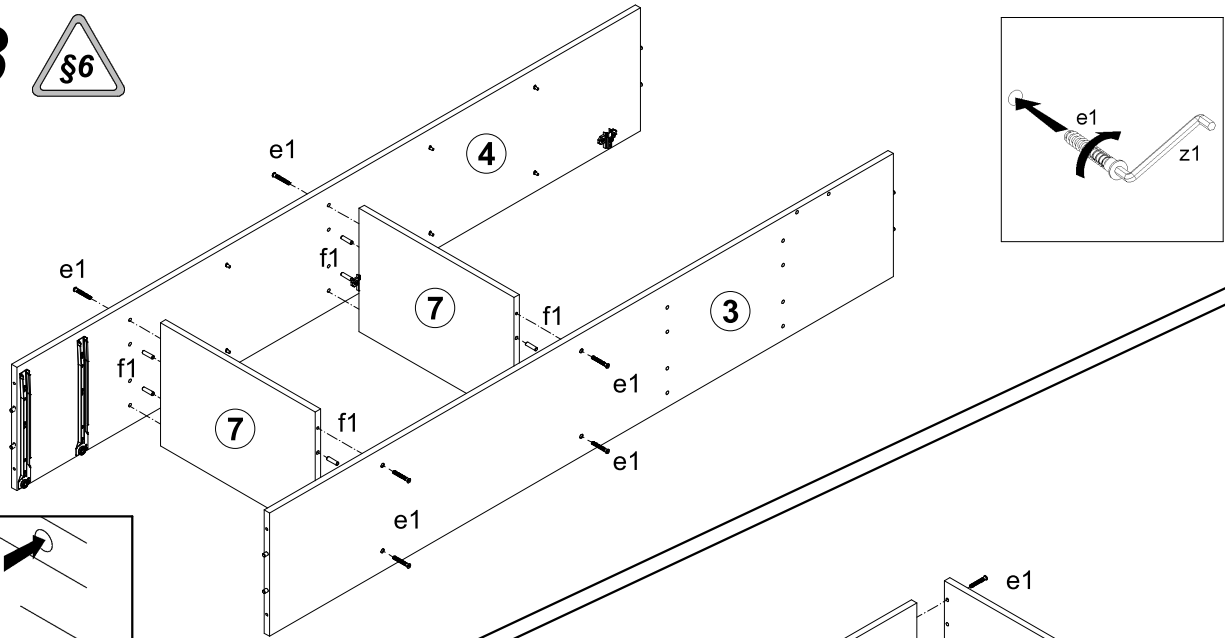

19

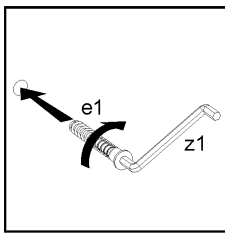
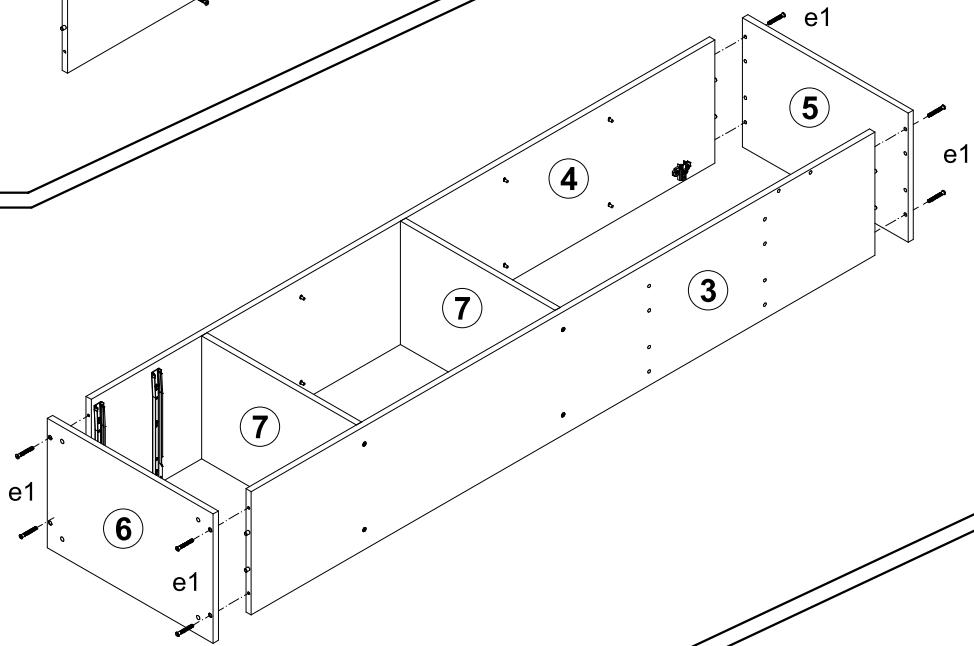

20

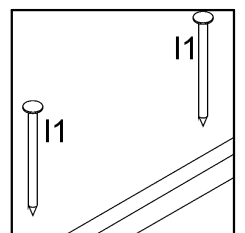
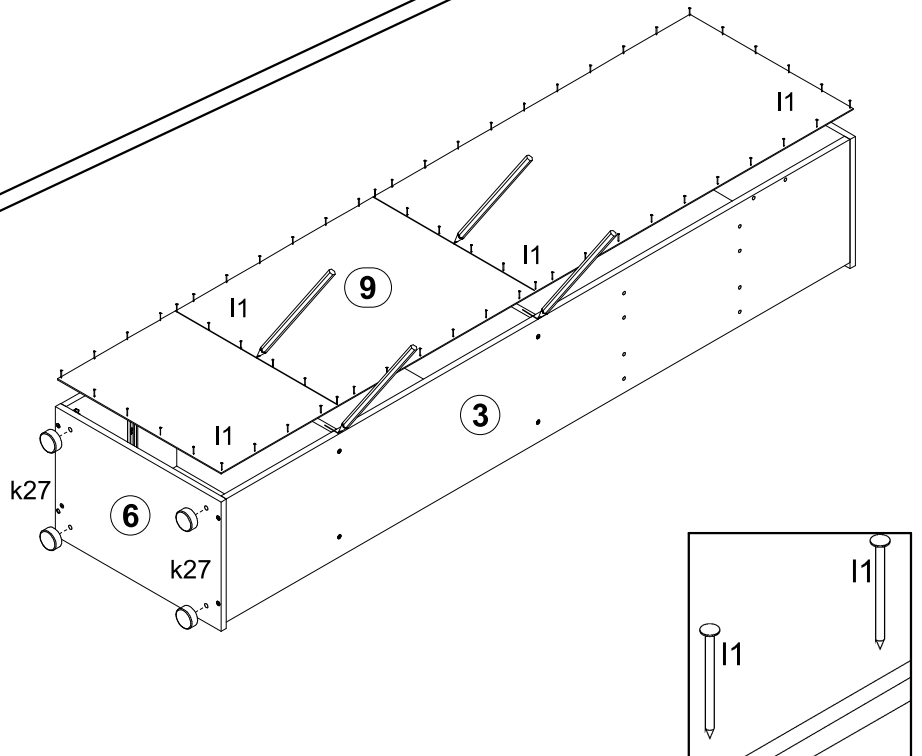
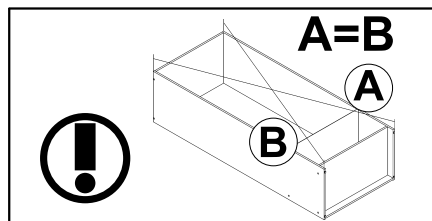

21

I

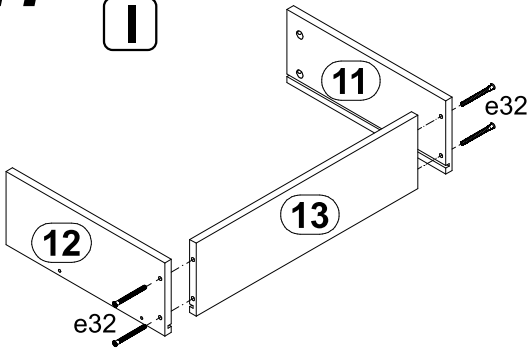

II

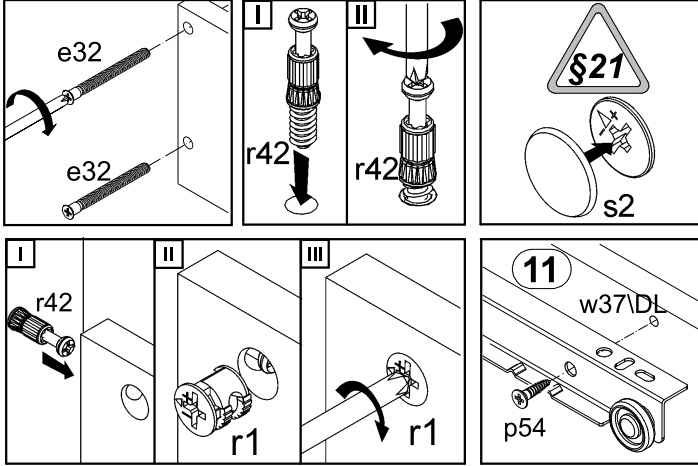
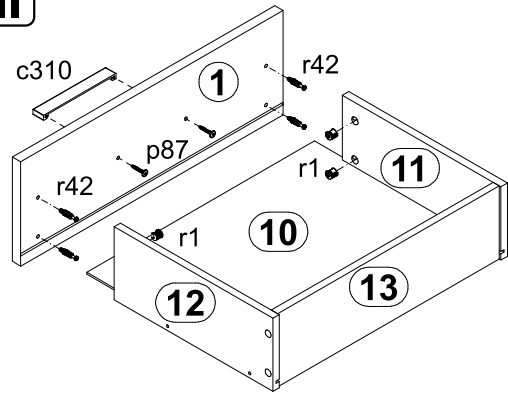

III

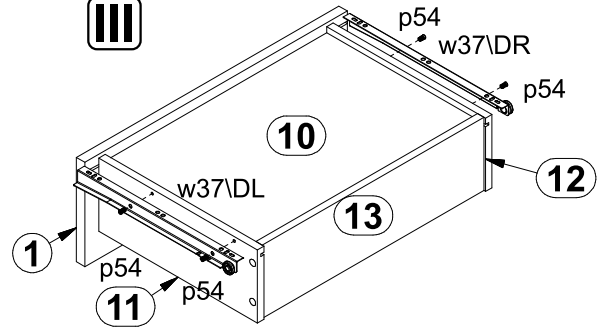

22

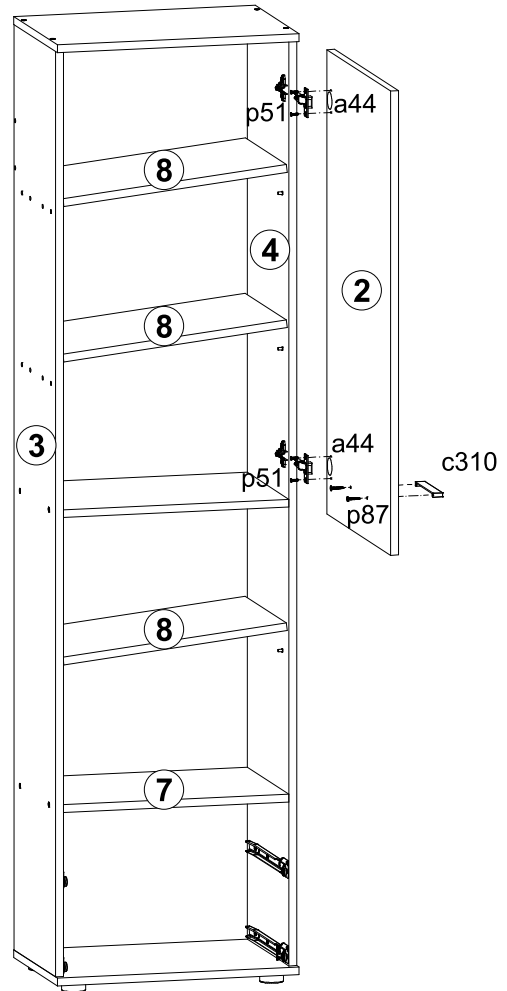
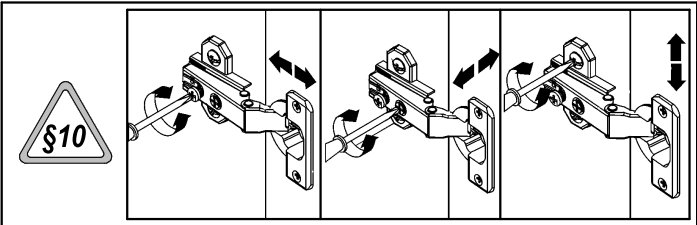
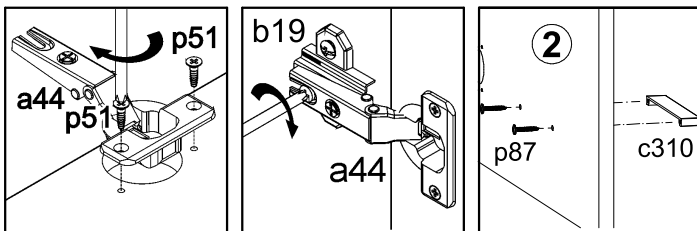
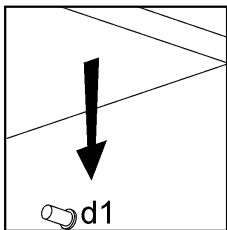

23

